

S Series - Rotary Ball Vibrator

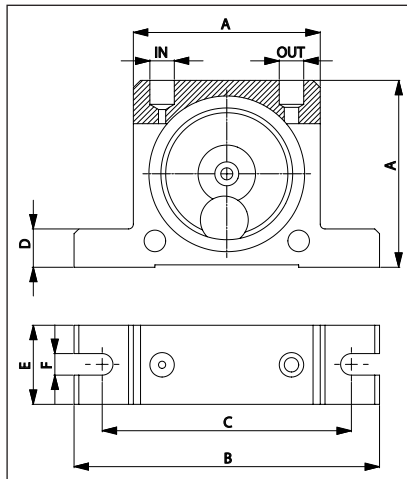

TECHNICAL DATA SHEET

Type	Overall dimension													Weight	
	A		B		C		D		E		F		IN-OUT		
	mm	inch	mm	inch	mm	inch	mm	inch	mm	inch	mm	inch		Kg	lbs
S8	50	1.97	86	3.39	68	2.68	12	0.47	20	0.79	7	0.28	1/8" GAS	0.13	0.29
S10	65	2.56	113	4.45	90	3.54	16	0.63	25	0.98	9	0.35	1/4" GAS	0.26	0.57
S13									28	1.10				0.30	0.66
S16									33	1.30				0.53	1.17
S20	80	3.15	128	5.04	104	4.09	16	0.63	38	1.50	9	0.35	1/4" GAS	0.63	1.39
S25									45	1.77				1.13	2.49
S30	100	3.94	160	6.30	130	5.12	20	0.79	50	1.97	11	0.43	3/8" GAS	1.34	2.95
S36															



Type	Features														
	Vibration			F.c. max						Air consumption					
	Vpm			2bar = 29psi		4bar = 58psi		6bar = 87 psi		2bar = 29psi		4bar = 58psi		6bar = 87 psi	
	2bar = 29psi	4bar = 58psi	6bar = 87 psi	Kg	lbs	Kg	lbs	Kg	lbs	l/min	CF/min	l/min	CF/min	l/min	CF/min
S8	25500	31000	35000	13	29	26	57	36	79	83	2.9	145	5.1	195	6.9
S10	22500	28000	34000	25	55	47	103	71	156	92	3.2	150	5.3	200	7.1
S13	15000	18500	22500	32	70	55	121	87	191	94	3.3	158	5.6	225	7.9
S16	13000	17000	19500	45	99	80	176	110	242	122	4.3	200	7.1	280	9.9
S20	10500	14500	16500	72	158	122	268	172	378	130	4.6	230	8.1	340	12.0
S25	9200	12200	14000	93	205	157	345	205	451	160	5.7	290	10.2	425	15.0
S30	7800	9700	12500	151	332	247	543	321	706	215	7.6	375	13.2	570	20.1
S36	7300	9000	10000	206	453	315	693	405	891	260	9.2	475	16.8	675	23.8

APPLICATION	HOPPER AND SILO - SCREEN - VIBRATING TABLE - CHUTE
POWDER	DRY AND GRANULAR
PROBLEM SOLVING	FRICTION REDUCTION - SEPARATION
FEATURES	
DUTY CICLE	CONTINUOUS
WORKING PRESSURE	FROM 2 BAR TO 6 BAR (FROM 29 PSI TO 87 PSI)
PNEUMATIC CIRCUIT	FILTER+FLOW CONTROL VALVE+LUBRIFICATION+3/2 WAYS VALVE
AIR SUPPLY QUALITY	CLASS 5.4.4.
WORKING TEMPERATURE	FROM -20°C to 200°C (FROM -4°F TO 392°F)
MAX NOISE LEVEL	90 dB(A)
TECHNOLOGY	ROTARY VIBRATION - HIGH FREQUENCY
ATEX	II 2D cT(x) / II 2G cT(x)
MATERIAL	ALUMINUM BODY AND ZINC PLATE COVER